

MANHOLE COVER REGISTRO D-400
 LIGHT TRAFFIC

Delta

T2066A

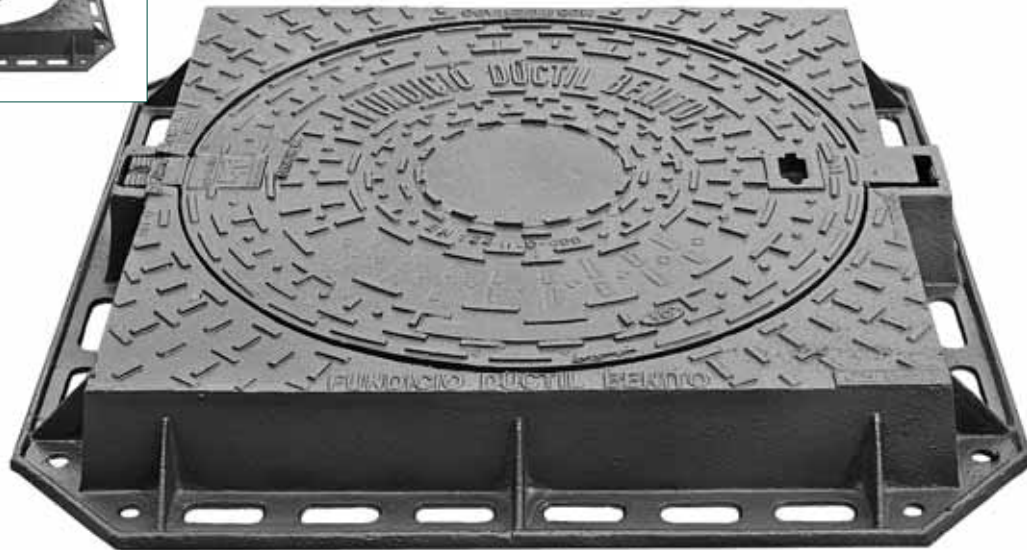

PATENTED MODEL

DIMENSIONS

| REFERENCE | | A x B Ext. frame length | H Depth | ØC Cover length | ØP Clear opening | CHARACTERISTICS | UNITS PER PALETTE |
|--------------|-----------------------------|----------------------------|------------|--------------------|---------------------|---|----------------------|
| DELTA T2066 | Cover rond frame | Ø860 | 100 | Ø650 | Ø600 | D-400 | 10 |
| DELTA T2066K | Cover square frame | 850 x 850 | 100 | Ø650 | Ø600 | Security spring closure. Sound-proof joint. Hinged. | 10 |
| DELTA T2066A | Cover square apparent frame | 850 x 850 | 100 | Ø650 | Ø600 | Blockage at 90°. | 10 |

CHARACTERISTICS

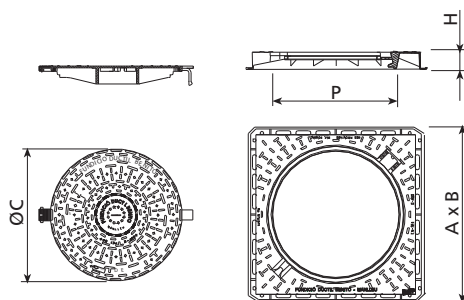

Made of **ductile iron**. Fulfils the requirements of European standards **EN-124**.

D-400 class. Suitable for use in **paved roads, pedestrian streets, parking zones** for all type of road vehicles. 40 tonnes test load.

Black paint coating.

Slip-proof surface.

Frame provided with a sound-proof joint.

Security spring closure that guarantees the locking and the perfect fitting of manhole cover and frame.

Hinge for an easy opening and a secure exploration. Manhole cover blockage at 90°; and maximum opening at 130°.

